



DISTRIBUTED BY:

1377 Stonefield Court
Alpharetta, GA 30004

T 800.237.9773
F 800.200.4379
www.fryreglet.com

12342 Hawkins Street
Santa Fe Springs, CA 90670

Orlando PH: 407-423-3477 FX: 407-423-3668
Jacksonville PH: 904-394-3190 FX: 904-394-3191
Tampa PH: 813-719-3625 FX: 813-759-0290

West Palm PH: 561-721-1110 FX: 561-721-1155
Wildwood PH: 352-748-0445 FX: 352-748-0447

1-800-940-7732 www.rselliott.com

Price List Effective March 2019 Extruded Aluminum Drywall & Plaster Moldings and Trim Terms & Conditions

All prices are per linear foot. Pieces are sold in 10 foot lengths.

Terms

Terms are net 30 days from date of invoice to accounts in good standing and will be established based on credit for new accounts.

Changes or Cancellations

Once an order begins processing, cancellation charges may be applicable.

Freight

Shipments are F.O.B. factory (Santa Fe Springs, CA or Alpharetta, GA). Title for all goods shall pass to the purchaser immediately upon delivery to the carrier. Responsibility for filing freight claims rests with the purchaser.

Claims

Claims for material received out of specification or damaged in freight must be made within 5 days of receipt. Fry Reglet will not accept any unauthorized charges for defective or damaged materials, cost of repair, cleanup, or use of equipment. An agreed upon procedural and monetary resolution, between Fry Reglet and the purchaser, must be signed and in place prior to a repair.

Available Finishes

Chemical conversion coating (Chem Film)

Multi-step cleaning and metal preparation process that acts as a protective coating until primer and paint can be applied.

Clear Anodized

Meets or exceeds Aluminum Association Designation AA-M11-C31-A21.

Color Anodized

Please call for availability and quote. Color anodized is an interior only finish.

Primer

Factory baked on primer.

Powder Paint

A Superior finish designed for commercial and

Architectural applications. Select from any Fry Reglet standard powder coat colors and primer finish. Orders under 500 LF subject to a net \$250.00 setup charge.

Touch Up Paint

Touch up paint is available for purchase at \$40.39 net per quart. Please specify interior or exterior application.

Kynar Paint (70% resin solids)

Warrantied paint finish, primarily used in exterior applications due to its excellent resistance to chemical and UV exposure.

Custom Color Matches

Are available in powder paint, Kynar paint and color anodized finish. Please call for price quote.

Custom Extrusions

Please contact Fry Reglet for pricing and lead times. Custom extrusions require a minimum order, additional lead time and may be shipped with a maximum of 10% overage.

Factory fabricated intersections and custom assemblies are available.

Radius technology

Fry Reglet can curve most profiles to your specifications. Contact us for technical assistance.

Quotations are required for all custom fabrication.

Returns

At Fry Reglet's sole discretion, prior authorization is required for return of stock material and will only be considered for return within 90 days of invoice date. Material is subject to inspection; a 20% restocking charge will apply. Contact customer service if over 90-day window-additional restock charge may apply. Nonstock items cannot be accepted for return (includes fabricated, painted, or color anodized items). Invoices under \$50.00 cannot be accepted for return. Please be sure to send invoices (copy) with all RMA's being returned for credits to be properly applied. Custom orders will not be accepted for return.

****If this price list is over 12 months old, please call Customer Service to verify information.**

Drywall Moldings - Reveals

(Priced per linear foot)

Reveal Molding



Molding Number	Clr Anod or Chem Film Non-Vented	Clr Anod or Chem Film Vented	Factory Painted Finish Non-Vented	Factory Painted Finish Vented	LF per Box	Pounds per foot
DRM-25-25	2.39	-	3.60	-	300	.15
DRM-50-125	2.41	-	3.64	-	300	.15
DRM-50-25	2.80	-	4.01	-	300	.17
DRM-50-375	2.88	-	4.02	-	300	.17
DRM-50-50*	3.00	3.36	4.23	4.79	300	.19
DRM-50-625**	3.07	3.48	4.37	4.86	250	.20
DRM-50-75***	3.21	3.57	4.50	4.99	300	.21
DRM-50-100	3.36	3.76	4.78	5.26	200	.22
DRM-50-150	3.73	4.18	5.22	5.72	300	.25
DRM-50-200	4.07	4.54	5.60	6.13	200	.28
DRM-50-250	4.53	5.00	6.29	6.83	100	.32
DRM-50-300	5.02	5.56	6.94	7.55	100	.36
DRM-50-400	6.83	7.41	9.16	9.84	100	.38
DRM-625-25	2.88	-	4.12	-	250	.18
DRM-625-375	3.00	-	4.30	-	250	.19
DRM-625-50*	3.17	3.56	4.51	5.00	250	.20
DRM-625-625**	3.27	3.68	4.69	5.19	300	.21
DRM-625-75***	3.36	3.76	4.80	5.28	300	.22
DRM-625-100	3.56	3.97	5.00	5.49	300	.24
DRM-625-1250	3.64	4.02	5.13	5.63	300	.24
DRM-625-150	3.91	4.34	5.42	5.92	200	.26
DRM-625-200	4.31	4.75	5.89	6.44	200	.31
DRM-625-250	4.65	5.13	6.36	6.94	100	.33
DRM-625-300	5.28	5.80	7.22	7.76	100	.38
DRM-625-400	6.57	7.35	9.21	9.97	100	.38
DRM-625-600	7.85	8.48	11.22	11.96	100	.54

End Caps Available:
\$5.81 each clear or chem
\$8.06 each painted

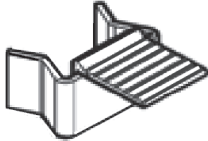

End Cap with Flange

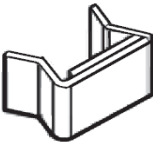

End Cap No Flange

* Accepts the DRM SNAP-IN/375
** Accepts the DRM SNAP-IN/50
***Accepts the DRM SNAP-IN/625

"F" Reveal Molding



DRMF-50-125	1.90	-	3.08	-	300	.12
DRMF-50-25	2.03	-	3.25	-	300	.13
DRMF-50-375	2.09	-	3.31	-	300	.14
DRMF-50-50*	2.23	2.58	3.39	3.85	300	.15
DRMF-50-625**	2.37	2.77	3.43	3.91	300	.14
DRMF-50-75***	2.40	2.81	3.50	4.00	300	.16
DRMF-50-100	2.58	3.00	3.68	4.18	300	.18
DRMF-625-375	2.28	-	3.31	-	300	.14
DRMF-625-50*	2.39	2.80	3.47	3.97	300	.16
DRMF-625-625**	2.53	2.89	3.57	4.05	300	.17
DRMF-625-75***	2.59	3.01	3.72	4.22	300	.18
DRMF-625-100	2.78	3.17	4.18	4.65	300	.19
DRMF-625-150	3.39	3.84	4.87	5.42	300	.24
DRMF-625-200	4.05	4.53	5.67	6.29	200	.27
DRMF-625-300	4.66	5.22	6.56	7.24	100	.35

* Accepts the DRM SNAP-IN/375
** Accepts the DRM SNAP-IN/50
***Accepts the DRM SNAP-IN/625

Drywall Moldings - Reveals

(Priced per linear foot)

"Snap In" Reveal

Used with DRM & DRMF

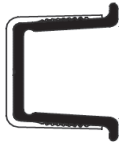

Molding Number	Clr Anod or Chem Film Non-Vented	Clr Anod or Chem Film Vented	Factory Painted Finish Non-Vented	Factory Painted Finish Vented	LF per Box	Pounds per foot
DRM SNAP-IN/375	3.36	-	4.50	-	300	.10
DRM SNAP-IN/50	3.43	-	4.63	-	300	.10
DRM SNAP-IN/625	3.54	-	4.73	-	300	.10

"Z" Reveal Molding



DRMZ-25-25	1.40	-	2.46	-	250	.07
DRMZ-50-125	1.51	-	2.64	-	250	.09
DRMZ-50-25	1.60	-	2.75	-	250	.10
DRMZ-50-375	1.70	-	2.77	-	250	.11
DRMZ-50-50	1.76	2.14	2.85	3.42	250	.11
DRMZ-50-625	1.90	2.28	3.00	3.47	250	.12
DRMZ-50-75	1.96	2.37	3.04	3.53	250	.13
DRMZ-50-100	2.08	2.46	3.27	3.74	250	.13
DRMZ-50-150	2.41	2.87	3.91	4.45	250	.16
DRMZ-50-200	2.85	3.32	4.45	5.01	250	.19
DRMZ-625-25	1.61	-	2.71	-	250	.09
DRMZ-625-375	1.74	-	2.84	-	250	.10
DRMZ-625-50	1.86	2.26	2.90	3.42	250	.12
DRMZ-625-625	1.98	2.38	3.04	3.53	250	.13
DRMZ-625-75	2.06	2.43	3.10	3.63	250	.13
DRMZ-625-100	2.21	2.58	3.33	3.85	250	.14
DRMZ-625-1250	2.38	2.81	3.51	4.04	250	.16
DRMZ-625-200	3.01	3.48	4.62	5.18	250	.21
DRMZ-100-100	2.41	2.84	3.63	4.11	250	.16

Base



DRMB-50-400	5.04	-	7.03	-	100	.39
DRMB-625-250	3.99	-	5.55	-	100	.30
DRMB-625-300	4.39	-	6.10	-	100	.34
DRMB-625-400	5.18	-	7.14	-	100	.40
DRMB-625-600	7.66	-	10.27	-	50	.61
DRMB Endcap	29.42	-	35.74	-	-	-
DRMB End plate	5.48	-	7.83	-	-	-

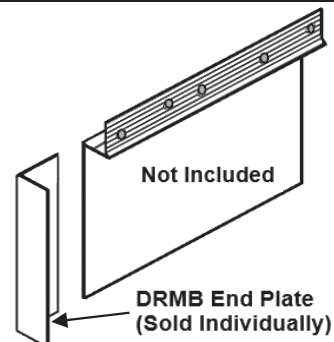
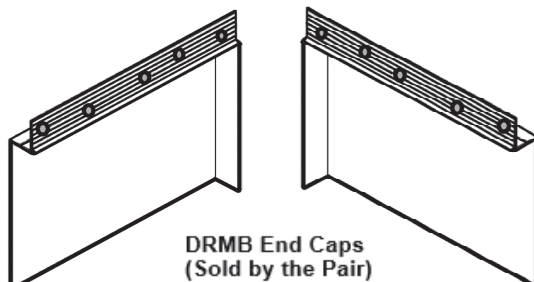

Drywall Moldings - Reveals

(Priced per linear foot)

Flush Base w/ Reveal



Molding Number	Clr Anod or Chem Film Non-Vented	Clr Anod or Chem Film Vented	Factory Painted Finish Non-Vented	Factory Painted Finish Vented	LF per Box	Pounds per foot
DRMBFL5025400	9.23	-	12.33	-	50	.67
DRMBFL5050400	9.38	-	12.49	-	50	.68
DRMBFL62525400	10.06	-	13.16	-	50	.71
DRMBFL62550400	10.25	-	13.73	-	50	.72
DRMBFL Endcap	29.42	-	35.74	-	-	-
DRMBFL End plate	5.48	-	7.83	-	-	-

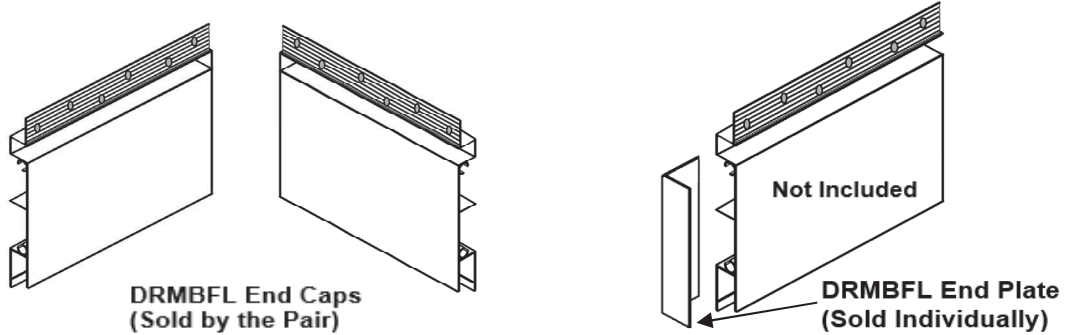

Drywall Control Joints



Allows 3/16" movement



Allows 3/8" movement

DRM-50-25 2-PC	5.11	-	7.72	-	300	.25
DRM-50-50 2-PC	5.28	-	7.90	-	300	.27
DRM-50-75 2-PC	5.50	-	8.14	-	200	.28
DRM-50-150 2-PC	6.11	-	8.71	-	150	.33
DRM-50-50 3-PC	7.43	-	11.36	-	300	.35
DRM-50-75 3-PC	7.66	-	11.56	-	200	.37
DRM-50-100 3-PC	8.06	-	11.99	-	150	.40
DRM-50-150 3-PC	8.24	-	12.18	-	150	.41

Stepped Outside Corner

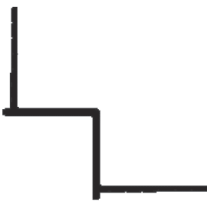

DRMW-50-50	2.46	-	3.78	-	250	.15
DRMW-50-150	3.17	-	4.66	-	250	.20
DRMW-625-625	2.64	-	3.99	-	250	.16
DRMW-150-150	7.66	-	9.14	-	100	.33

Step Trim



DMST-50-50	3.27	-	4.84	-	250	.22
DMST-625-625	3.30	-	4.87	-	250	.22

"V" Reveal Molding



DRMV-25	2.00	-	3.23	-	250	.11
DRMV-75	2.77	-	4.05	-	250	.17
DRMV-100	3.07	-	4.37	-	250	.20

Drywall Moldings - Reveals

(Priced per linear foot)

Reverse "V" Reveal Molding



Molding Number	Clr Anod or Chem Film Non-Vented	Clr Anod or Chem Film Vented	Factory Painted Finish Non-Vented	Factory Painted Finish Vented	LF per Box	Pounds per foot
DRMVR-100	3.00	-	4.37	-	250	.19

"W" Reveal

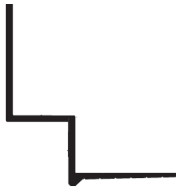

DRWT-50-50	2.53	-	3.84	-	250	.17
DRWT-75-75	2.85	-	4.18	-	250	.19
DRWT-200-200	5.70	-	7.97	-	100	.44

Reveal / Picture Hanger

DRMH-50 Reveal

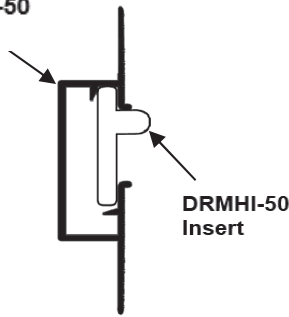

DRMH-50	4.70	-	-	-	200	.35
DRMHI-50 Insert*	4.63	-	-	-	-	-

* Weight limit per each Picture Hanger Insert is approximately 50-75 lbs.

Wall Covering Base/Termination



WCTBT125-217C	2.53	-	5.31	-	200	.16
---------------	------	---	------	---	-----	-----

Wall Covering Field



WCTF125-217C	4.28	-	5.46	-	200	.27
--------------	------	---	------	---	-----	-----

Wall Covering Outside Corner

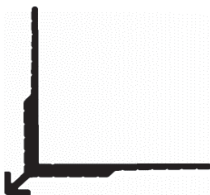

WCTOSC125-217C	4.81	-	6.02	-	200	.30
----------------	------	---	------	---	-----	-----

Drywall Moldings - Reveals

(Priced per linear foot)

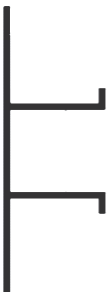
Reveal Channel Screed	Molding Number	Clr Anod or Chem Film Non-Vented	Clr Anod or Chem Film Vented	Factory Painted Finish Non-Vented	Factory Painted Finish Vented	LF per Box	Pounds per foot
	DCS-50-50	3.11	3.54	4.45	4.94	250	.22
	DCS-50-75	3.32	3.72	4.86	5.34	200	.24
	DCS-50-100	3.54	3.92	4.93	5.42	200	.26
	DCS-50-150	3.91	4.34	5.42	5.92	100	.29
	DCS-50-200	4.33	4.80	5.92	6.49	100	.32
	DCS-50-300	6.44	6.95	8.34	8.94	100	.47
	DCS-50-400	7.41	7.97	9.74	10.38	100	.54
	DCS-625-50	3.56	3.97	5.07	5.56	200	.24
	DCS-625-75	3.80	4.20	5.31	5.83	200	.28
	DCS-625-100	3.99	4.37	5.52	6.02	200	.27
DCS-625-150	4.39	4.84	6.04	6.54	100	.30	
DCS-625-200	4.79	5.26	6.56	7.12	100	.33	
DCS-625-250	5.19	5.65	7.12	7.69	100	.36	
DCS-625-300	6.46	6.96	8.63	9.19	100	.49	
DCS-625-400	7.45	8.22	9.97	10.63	100	.56	
DCS-625-600	11.22	11.91	14.58	15.37	100	.91	

End Caps Available:
\$5.81 each clear or chem \$8.06 each painted

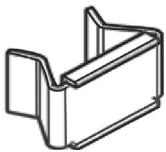



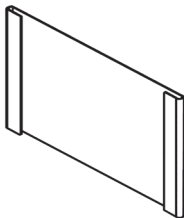

End Cap



Connector Clip

* 1 connector clip per stick

"F" Reveal	Molding Number	2.80	3.21	4.06	4.57	300	.18
	FDM-50-75	2.80	3.21	4.06	4.57	300	.18
	FDM-625-50	3.01	3.39	4.31	4.80	300	.19
	FDM-625-75	3.32	3.72	4.63	5.12	300	.19
	FDM-625-100	3.64	4.02	5.01	5.49	250	.24
	FDM-625-150	3.99	4.39	5.45	6.01	250	.24
	FDM-625-250	4.50	4.95	6.23	6.77	250	.30
	FDM-625-300	4.88	5.40	6.78	7.41	200	.33

"T" Molding	Molding Number	1.90	2.28	3.02	3.48	300	.13
 <p>TDM</p>  <p>T-BATTEN</p>  <p>T-Piece</p>	TDM-50-50	1.90	2.28	3.02	3.48	300	.13
	TDM-50-75	2.22	2.58	3.30	-	300	.14
	TDM-50-1125	2.41	2.84	3.84	4.31	300	.16
	TDM-50-150	2.85	3.27	4.25	4.72	300	.17
	TDM-625-50	2.03	2.40	3.08	3.58	300	.13
	TDM-625-75	2.26	2.62	3.40	3.89	300	.14
	TDM-625-1125	2.56	2.92	3.86	4.33	300	.17
	T-Batten	4.20	-	-	-	300	.20
	T-Piece	2.84	-	4.00	-	238 3/4	.14

Note: T-piece 95 1/2 inches long

Drywall Moldings - Trims

(Priced per linear foot)

"X" Molding

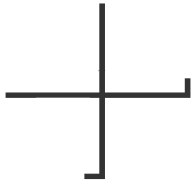

Molding Number	Clr Anod or Chem Film Non-Vented	Clr Anod or Chem Film Vented	Factory Painted Finish Non-Vented	Factory Painted Finish Vented	LF per Box	Pounds per foot
XDM-50-50	3.00	-	4.43	-	100	.19
XDM-625-625	3.08	-	4.50	-	100	.21

"W" Molding

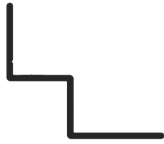

WDM-50-50-625	2.36	-	3.66	-	250	.18
WDM-50-75	2.62	3.03	3.97	4.43	250	.18
WDM-625-75	2.78	3.17	4.06	4.54	250	.19
WRM-75-75-625	2.88	3.27	4.72	5.22	250	.19

Corner Trim



DMCT-375	2.84	-	4.12	-	500	.17
DMCT-1250	5.04	-	6.53	-	250	.40

Ceiling Trim

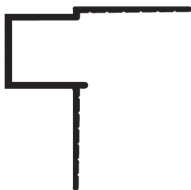

DRMCT-50-50	2.87	-	4.19	-	200	.20
DRMCT-625-75	3.64	-	5.32	-	200	.20
DRMCT-625-100	4.11	-	5.02	-	200	.20

"L" Trim Molding



DRML-50	1.42	-	2.52	-	250	.08
DRML-625	1.51	-	2.59	-	250	.09
DRML-75	1.60	-	2.78	-	250	.10
DRML-100	1.76	-	3.05	-	250	.11
DRML-1250	1.95	-	3.27	-	250	.12
DRML-150	2.37	-	3.51	-	250	.16
DRML-1625	2.55	-	3.66	-	250	.16
DRML-200	2.98	-	4.40	-	250	.20
DRML-250	3.27	-	4.84	-	250	.23
DRML-300	3.86	-	5.27	-	250	.29

Drywall Moldings -Trims

(Priced per linear foot)

Edge Trim



Molding Number	Clr Anod or Chem Film Non-Vented	Clr Anod or Chem Film Vented	Factory Painted Finish Non-Vented	Factory Painted Finish Vented	LF per Box	Pounds per foot
DMET-50	1.46	-	2.58	-	250	.08
DMET-100	1.78	-	2.86	-	250	.11
DMET-150	2.21	-	3.48	-	250	.14

Edge Trim 2



DRME-50	2.05	-	3.09	-	250	.13
DRME-625	2.06	-	3.14	-	250	.14
DRME-1250	2.58	-	4.06	-	250	.17

Pocket Trim



DMPT-75	2.22	-	3.29	-	300	.14
---------	------	---	------	---	-----	-----

Radius Corner Trim



RCT-50	3.43	-	5.18	-	200	.23
--------	------	---	------	---	-----	-----

Multiple Step Trim

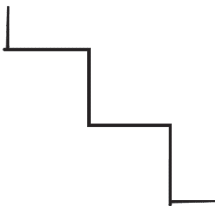

DMOS-625	3.60	-	5.02	-	250	.24
DMOS-150	11.57	-	13.84	-	100	.97

"J" Molding



JDM-50	1.92	-	3.40	-	500	.12
JDM-625	2.03	-	3.51	-	500	.13
JDM625-50 *	2.26	-	4.79	-	200	.14
J-5625 **	3.60	-	5.45	-	200	.25
J-1625 ***	2.43	-	4.38	-	200	.16

* Old Part # 2054

** Old part # 1262 (5625 = 9/16")

*** Old Part Number 1360 (1625 = 1 5/8")

Drywall Moldings - Trims

(Priced per linear foot)

Drywall Molding End Closure	Molding Number	Clr Anod or Chem Film Non- Vented	Clr Anod or Chem Film Vented	Factory Painted Finish Non- Vented	Factory Painted Finish Vented	LF per Box	Pounds per foot
	DMEC-200	3.21	-	4.80	-	200	.23
	DMEC-3500	4.43	-	6.65	-	200	.32
	DMEC-3750	5.28	-	7.35	-	100	.41
	DMEC-4625	6.08	-	8.39	-	100	.47
	DMEC-4875	6.32	-	8.66	-	100	.49
	DMEC-7250	12.79	-	17.04	-	40	1.09

Top Track	DMTT-625-3750	6.90	-	8.95	-	100	.55
-----------	---------------	------	---	------	---	-----	-----



Protruding Edge Termination	DRMPET 375	2.59	-	5.09	-	300	.20
	DRMPET 100	3.26	-	5.82	-	200	.20



DRMPET 375



DRMPET100

Protruding Edge Outside Corner	DRMPWR 100-75	7.87	-	10.39	-	100	.47
--------------------------------	---------------	------	---	-------	---	-----	-----



Protruding Edge Reveal	DRMPCR 100-100	7.69	-	10.26	-	100	.41
------------------------	----------------	------	---	-------	---	-----	-----



Drywall Moldings - Corners

(Priced per linear foot)

Stepped Outside Corner

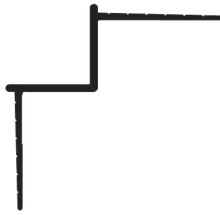

Molding Number	Clr Anod or Chem Film Non-Vented	Clr Anod or Chem Film Vented	Factory Painted Finish Non-Vented	Factory Painted Finish Vented	LF per Box	Pounds per foot
DRMW-50-50	2.46	-	3.78	-	250	.15
DRMW-50-150	3.17	-	4.66	-	250	.20
DRMW-625-625	2.64	-	3.99	-	100	.33
DRMW-150-150	7.66	-	9.14	-	250	.16

Multiple Stepped Outside Corner

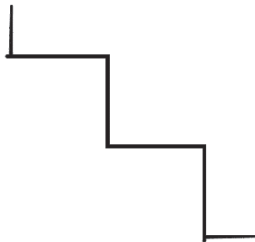

DMOS-625	3.60	-	5.02	-	250	.24
DMOS-150	11.57	-	13.84	-	100	.97

Beveled Corner



DMBC-75	2.10	-	3.29	-	250	0.14
---------	------	---	------	---	-----	------

Curved Inside Corner

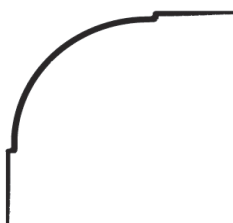

DRMC-IS-75	3.07	-	4.38	-	200	.20
DRMC-IS-100	3.51	-	4.87	-	200	.25
DRMC-IS-150	4.22	-	5.69	-	200	.31
DRMC-IS-200	5.18	-	6.91	-	200	.41
DRMC-IS-300	7.45	-	9.95	-	100	.60
DRMC-IS-400	10.36	-	13.36	-	50	.74
DRMC-IS-600	21.50	-	24.95	-	50	1.89

Curved Outside Corner

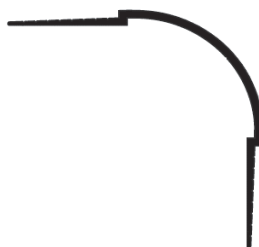

DRMC-OS-625	2.55	-	3.85	-	200	.17
DRMC-OS-75	2.89	-	4.22	-	200	.20
DRMC-OS-100	3.35	-	4.72	-	200	.24
DRMC-OS-150	4.04	-	5.55	-	200	.30
DRMC-OS-200	5.00	-	6.62	-	100	.35
DRMC-OS-250	6.26	-	8.45	-	100	.42
DRMC-OS-300	7.24	-	9.67	-	100	.55
DRMC-OS-400	10.13	-	13.14	-	50	.84

Column Collar

Priced per Unit



Acoustical/
Drywall

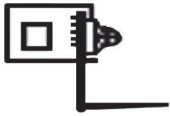

Drywall

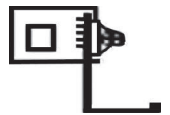

Plaster

Collar Size	Clear Anodized or Chem Film	*Factory Painted	Wgt. Per Collar
10" to 13 " Diameter	66.76	83.74	2
14" to 20 " Diameter	80.11	99.53	2
21" to 24 " Diameter	84.96	101.95	3
25" to 32 " Diameter	108.02	127.44	4
33" to 39 " Diameter	125.01	144.42	5
40" to 48 " Diameter	145.64	166.27	6

* Minimum Quantity Required.
Specify exact column diameter when order column collars.
Specify type - Acoustical, Plaster or Drywall. Specify white or dark bronze PVC spacer.

Reveal Column Ring

Priced per Unit (one full or two half circles)



Diameter	18"-24"	18"-24"	25"-32"	25"-32"
	Clear / CF	Paint	Clear / CF	Paint
Description				
DRWT-50-50	60.68	80.15	84.73	104.19
DRWT-75-75	60.68	80.15	84.73	104.19
WRM-75-75	58.39	79.00	81.29	101.90
WDM-50-50	58.39	79.00	81.29	101.90



Diameter	33"-39"	33"-39"	40"-49"	40"-49"
	Clear / CF	Paint	Clear / CF	Paint
Description				
DRWT-50-50	95.03	115.64	107.63	132.81
DRWT-75-75	95.03	115.64	107.63	132.81
WRM-75-75	93.89	113.35	106.48	133.96
WDM-50-50	93.89	113.35	106.48	133.96

*See Fry Reglet Design Guide or Product Brochure for complete product information.

Wall Angle Column Ring

Priced per Unit (one full or two half circles)



7/8" Drywall

Diameter	10"-13"	10"-13"	14"-17"	14"-17"	18"-24"	18"-24"
Description	C/CF	Paint	C/CF	Paint	C/CF	Paint
3/4" Wall Angle	38.84	58.26	42.48	61.90	57.04	77.68
7/8" Wall Angle	38.84	58.26	42.48	61.90	57.04	77.68



3/4" Acoustical

Diameter	25"-32"	25"-32"	33"-39"	33"-39"	40"-49"	40"-49"
Description	C/CF	Paint	C/CF	Paint	C/CF	Paint
3/4" Wall Angle	80.10	100.73	92.24	111.66	105.59	127.43
7/8" Wall Angle	80.10	100.73	92.24	111.66	105.59	127.43

*See Fry Reglet Design Guide or Product Brochure for complete product information.

Reveal Wall Angle Column Ring Priced per Unit (one full or two half circles)



Diameter	18"-24"	18"-24"	25"-32"	25"-32"
Description	C/F	Paint	C/F	Paint
PRM-75-75	60.68	80.10	83.74	101.95
PRZ-75-75	60.68	80.10	83.74	101.95

Diameter	33"-39"	33"-39"	40"-49"	40"-49"
Description	C/F	Paint	C/F	Paint
PRM-75-75	94.67	112.87	119.10	127.43
PRZ-75-75	94.67	112.87	119.10	127.43

*See Fry Reglet Design Guide or Product Brochure for complete product information.

Drywall Moldings - Acoustical (Priced per Linear Foot)

"W" Reveal Molding



Molding Number	Clr Anod or Chem Film Non-Vented	Clr Anod or Chem Film Vented	Factory Painted Finish Non-Vented	Factory Painted Finish Vented	LF per Box	Pounds per foot
WDM-50-50-625	2.36	-	3.66	-	250	.18
WDM-50-75	2.62	3.03	3.97	4.43	250	.18
WDM-625-75	2.78	3.17	4.06	4.54	250	.19
WRM-75-75-625	2.88	3.27	4.72	5.22	250	.19

Drywall / Acoustical Reveal



DRMAD-50-50	3.92	-	5.26	-	200	.26
DRMAD-50-75	4.20	-	5.49	-	200	.28

Acoustical Ceiling Trim



DRAT-75	1.78	-	3.71	-	500	.09
DRAT-100	2.03	-	4.38	-	500	.11

Acoustical Molding



FDA-50	3.29	-	4.61	-	100	.22
FDA-625	3.42	-	4.72	-	100	.22
FDA-75	3.58	-	4.91	-	100	.24

Drywall Moldings - Acoustical

(Priced per Linear Foot)

"W" Acoustical Reveal

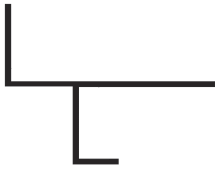

Molding Number	Clr Anod or Chem Film Non-Vented	Clr Anod or Chem Film Vented	Factory Painted Finish Non-Vented	Factory Painted Finish Vented	LF per Box	Pounds per foot
WARM-875-75	5.22	-	6.53	-	100	.28

"F" Acoustical Molding



FARM-875-75	4.08	-	5.83	-	100	.27
-------------	------	---	------	---	-----	-----

"J" Acoustical Molding



JAM-875	2.55	-	4.23	-	200	.16
---------	------	---	------	---	-----	-----

Bullnose



DBN-625-250	11.58	-	16.01	-	100	.90
DBN-625-3625	15.61	-	19.18	-	20	1.60

DMAT



DMAT30-500	19.29	-	26.57	-	20	1.20
DMAT45-500	18.48	-	25.77	-	20	1.20
DMAT Inside Welded Corner	129.86	-	-	-	-	-
DMAT Outside Welded Corner	145.64	-	-	-	-	-

Plaster Moldings - Reveals

(Priced per Linear Foot)

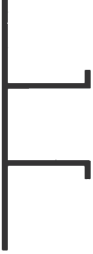
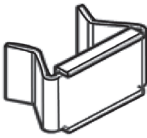
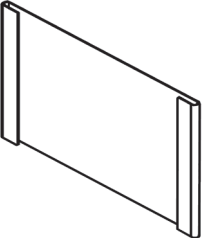
Control Screenshot / Control Joint	Molding Number	Clr Anod or Chem Film Non- Vented	Clr Anod or Chem Film Vented	Factory Painted Finish Non- Vented	Factory Painted Finish Vented	LF per Box	Pounds per foot
	DCS-50-50	3.11	3.54	4.45	4.94	250	.22
	DCS-50-75	3.32	3.72	4.86	5.34	200	.24
	DCS-50-100	3.54	3.92	4.93	5.42	200	.26
	DCS-50-150	3.91	4.34	5.42	5.92	100	.29
	DCS-50-200	4.33	4.80	5.92	6.49	100	.32
	DCS-50-300	6.44	6.95	8.34	8.94	100	.47
	DCS-50-400	7.41	7.97	9.74	10.38	100	.54
	DCS-625-50	3.56	3.97	5.07	5.56	200	.24
	DCS-625-75	3.80	4.20	5.31	5.83	200	.28
	End Caps Available: \$5.81 each clear or chem \$8.06 each painted Weep Holes \$1.21 / LF	DCS-625-100	3.99	4.37	5.52	6.02	200
DCS-625-150		4.39	4.84	6.04	6.54	100	.30
DCS-625-200		4.79	5.26	6.56	7.12	100	.33
DCS-625-250		5.19	5.65	7.12	7.69	100	.36
DCS-625-300		6.46	6.96	8.63	9.19	100	.49
DCS-625-400		7.45	8.22	9.97	10.63	100	.56
DCS-625-600		11.22	11.91	14.58	15.37	100	.91
PCS-25-75		3.00	3.48	4.51	5.09	250	.20
PCS-25-150		3.58	4.02	5.33	5.86	200	.23
PCS-375-50		3.24	3.60	4.52	5.01	250	.21
 <p>End Cap</p>	PCS-375-75	3.42	3.84	4.85	5.33	200	.22
	PCS-375-100	3.64	4.02	5.34	5.85	200	.24
	PCS-375-150	4.04	4.50	5.68	6.23	200	.27
	PCS-375-300	6.38	7.00	8.37	9.10	100	.45
	PCS-75-50	3.58	4.00	5.12	5.61	200	.25
	PCS-75-75	3.71	4.07	5.27	5.72	300	.27
	PCS-75-100	4.01	4.39	5.71	6.23	200	.28
	PCS-75-150	4.78	5.19	6.56	7.10	200	.34
	PCS-75-200	5.18	5.64	7.12	7.69	200	.38
	PCS-75-250	5.61	6.07	7.78	8.37	100	.41
 <p>Connector Clip</p>	PCS-75-300	6.49	7.00	8.65	9.21	100	.50
	PCS-75-400	7.42	7.98	10.14	10.78	100	.58
	PCS-75-600	11.25	11.94	14.60	15.40	100	.88
	PCS-100-75	4.51	4.88	6.13	6.63	100	.30
	PCS-100-100	4.72	5.17	6.56	7.10	100	.31
	PCS-100-300	7.66	8.17	10.14	10.73	100	.54
	PCS-150-150	5.86	6.31	8.06	8.63	100	.40

Note: Insect Screen available for \$2.15/lf net price. One connector clip per stick. Additional connector clips are available for \$0.55 each.

Stucco Reveals & Moldings

(Priced per Linear Foot)

1/4" Channel Screed



Molding Number	Clr Anod or Chem Film Non-Vented	Clr Anod or Chem Film Vented	Factory Painted Finish Non-Vented	Factory Painted Finish Vented	LF per Box	Pounds per foot
PCS-75-25/25	2.90	-	4.51	-	200	.20

"V" Reveal Molding



PCSV-75	6.82	-	8.86	-	100	.48
---------	------	---	------	---	-----	-----

"V" Reveal Molding



PCSV-75 Short	5.35	-	6.95	-	100	.38
---------------	------	---	------	---	-----	-----

"F" Reveal Molding



FPM-375-50	3.23	3.97	4.87	5.38	100	.17
FPM-75-50	2.78	3.17	4.06	4.54	300	.19
FPM-75-75	2.98	3.35	4.28	4.78	300	.21
FPM-75-100	3.17	3.56	4.53	5.02	250	.22
FPM-75-150	3.54	3.99	5.02	5.56	200	.25
FPM-75-200	4.39	4.86	6.02	6.61	200	.27
FPM-75-300	4.66	5.13	6.29	6.86	200	.30

"T" Reveal Molding



TRM



T-BATTEN



T-PIECE

TRM-75-75	2.19	2.57	3.48	3.99	300	.15
TRM-75-1125	2.61	3.04	3.91	4.45	300	.17
TRM-75-150	3.08	3.53	4.43	4.95	200	.20
T-BATTEN	4.49	-	-	-	300	.21
T-PIECE	2.84	-	4.00	-	238 3/4	.14

Note: T-piece 95 1/2 inches long

Stucco Reveals & Moldings / Drip Screeds

(Priced per Linear Foot)

Plaster Key Reveal Molding



Molding Number	Clr Anod or Chem Film Non-Vented	Clr Anod or Chem Film Vented	Factory Painted Finish Non-Vented	Factory Painted Finish Vented	LF per Box	Pounds per foot
PRZ-75-75	2.56	2.92	3.97	4.43	250	.17
PRZ-75-100	2.70	3.08	3.89	4.38	250	.18

Reveal Molding

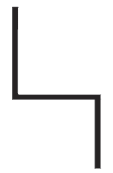

PRM-75-75	2.33	2.72	3.51	4.01	250	.16
PRM-75-9375 *	2.41	-	4.32	-	100	.16

* Old part # 1270 (9375 = 15/16")

Stucco Drip Screed



DS-75-75	3.58	4.00	5.12	5.61	200	.25
DS-375-875	4.22	4.63	5.60	6.07	200	.28

Thin Stucco Drip Screed



DS-75-200	6.36	6.83	8.64	9.16	100	.43
DS-75-300	7.24	7.74	9.14	9.73	100	.50

5/8" Drip Screed



DS-875-5/8-300	8.67	9.19	11.53	12.14	100	1.07
DS-875-150	6.72	7.14	8.34	8.89	100	.47
DS-875-200	7.89	8.36	9.49	10.06	100	.56
DS-875-300	8.89	9.38	10.78	11.38	100	.63

1054

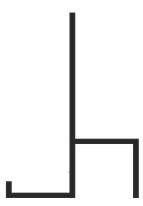

1054 **	4.72		6.35		100	.33
---------	------	--	------	--	-----	-----

** Old Part # 1054 (625 = 5/8")

Stucco Reveals & Moldings Soffit / Expansion

(Priced per Linear Foot)

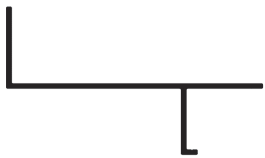
Soffit Molding	Molding Number	Clr Anod	Clr Anod	Factory	Factory	LF per Box	Pounds per foot
		or Chem Film Non-Vented	or Chem Film Vented	Painted Finish Non-Vented	Painted Finish Vented		
	WPM-75-200 *	4.33	4.80	5.91	6.36	100	.29
	WPM-50-300	5.95	6.46	7.89	8.48	100	.42
	WPM-75-300	6.02	6.53	7.91	8.50	100	.42
	WPM-75-400	7.14	7.69	9.47	10.14	100	.51
* Old Part # 1680							

"F" Drip Cap	F DRIP CAP **	3.58	-	5.28	-	200	.24
** Old part # 2221							

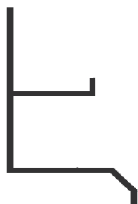

2 Piece Plaster Expansion Screed	DCS-50-75 2PC	4.20	-	6.82	-	200	.25
	DCS-50-150 2PC	4.81	-	7.43	-	150	.33
	PCS-75-25 2PC	4.37	-	6.96	-	200	.29
	PCS-75-50 2PC	4.53	-	7.14	-	200	.30
	PCS-75-75 2PC	4.78	-	7.36	-	200	.32
	PCS-75-100 2PC	5.04	-	7.68	-	200	.34
	PCS-75-150 2PC	5.40	-	8.01	-	150	.36
	PCS-75-200 2PC	5.84	-	8.45	-	100	.39
	Allows for 3/16" movement						

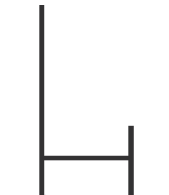

Drip Screed	DS-375-V-875	-	4.63	-	6.07	200	.28
	DS-75-V-75	-	4.00	-	5.61	200	.25
	DS-75-V-200	-	6.83	-	9.16	100	.43
	DS-75-V-300	-	7.74	-	9.73	100	.50
	DS-875-V-150	-	7.14	-	8.89	100	.47
	DS-875-V-200	-	8.36	-	10.06	100	.56
	DS-875-V-300	-	9.38	-	11.38	100	.63
							

Vented Soffit Molding	WPM-75-V-200 ***	-	4.80	-	6.36	100	.29
	WPM-50-V-300	-	6.46	-	8.48	100	.39
	WPM-75-V-300	-	6.53	-	8.50	100	.42
	WPM-75-V-400	-	7.69	-	10.14	100	.51
	Note: Insect Screen available on any vented product for \$2.15 / lf net price						
*** Old part # 1680V							
							

Soffit Vent

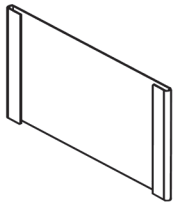

Connector Clip

Molding Number	Clr Anod or Chem Film Non-Vented	Clr Anod or Chem Film Vented	Factory Painted Finish Non-Vented	Factory Painted Finish Vented	LF per Box	Pounds per foot
DCS-50-V-50	-	3.54	-	4.94	250	.22
DCS-50-V-75	-	3.72	-	5.34	200	.24
DCS-50-V-100	-	3.92	-	5.42	200	.26
DCS-50-V-150	-	4.34	-	5.92	100	.29
DCS-50-V-200	-	4.80	-	6.49	100	.32
DCS-50-V-300	-	6.95	-	8.94	100	.47
DCS-50-V-400	-	7.97	-	10.38	100	.54
DCS-625-V-50	-	3.97	-	5.56	200	.24
DCS-625-V-75	-	4.20	-	5.83	200	.28
DCS-625-V-100	-	4.37	-	6.02	200	.27
DCS-625-V-150	-	4.84	-	6.54	100	.30
DCS-625-V-200	-	5.26	-	7.12	100	.33
DCS-625-V-250	-	5.65	-	7.69	100	.36
DCS-625-V-300	-	6.96	-	9.19	100	.49
DCS-625-V-400	-	8.22	-	10.63	100	.56
DCS-625-V-600	-	11.91	-	15.37	100	.91
PCS-25-V-75	-	3.48	-	5.09	250	.20
PCS-375-V-50	-	3.60	-	5.01	250	.21
PCS-375-V-75	-	3.84	-	5.33	200	.22
PCS-375-V-100	-	4.02	-	5.85	200	.24
PCS-375-V-150	-	4.50	-	6.23	200	.27
PCS-375-V-300	-	7.00	-	9.10	100	.45
PCS-75-V-50	-	4.00	-	5.61	200	.25
PCS-75-V-75	-	4.07	-	5.72	300	.27
PCS-75-V-100	-	4.39	-	6.23	200	.28
PCS-75-V-150	-	5.19	-	7.10	200	.34
PCS-75-V-200	-	5.64	-	7.69	200	.38
PCS-75-V-250	-	6.07	-	8.37	100	.41
PCS-75-V-300	-	7.00	-	9.21	100	.50
PCS-75-V-400	-	7.98	-	10.78	100	.58
PCS-75-V-600	-	11.94	-	15.40	100	.88
PCS-100-V-75	-	4.88	-	6.63	100	.30
PCS-100-V-100	-	5.17	-	7.10	100	.31
PCS-100-V-300	-	8.17	-	10.73	100	.54
PCS-150-V-150	-	6.31	-	8.63	100	.40

Note: Insect Screen available for \$2.15/lf net price. One connector clip per stick. Additional connector clips are available for \$0.55 each.

Stucco Reveals & Moldings / Stucco Trims / Corners (Priced per Linear Foot)

Fascia Corner Molding

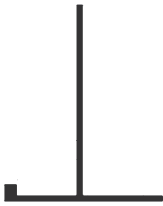

Molding Number	Clr Anod or Chem Film Non-Vented	Clr Anod or Chem Film Vented	Factory Painted Finish Non-Vented	Factory Painted Finish Vented	LF per Box	Pounds per foot
FCM-50	3.71	-	5.00	-	100	.30
FCM-75	3.97	-	5.27	-	100	.31

"J" Molding



JDM-50	1.92	-	3.40	-	500	.12
JDM-625	2.03	-	3.51	-	500	.13
JDM625-50 *	2.26	-	4.79	-	200	.14
JPM-75	2.09	-	3.58	-	500	.14
JPM-75-300	3.56	-	5.11	-	500	.26
JPM-100	2.22	-	3.74	-	500	.14
J-5625 **	3.60	-	5.45	-	200	.25
J-1625 ***	2.43	-	4.38	-	200	.16

* Old Part # 2054

** Old part # 1262 (5625 = 9/16")

*** Old Part Number 1360 (1625 = 1 5/8")

"X" Corner Molding

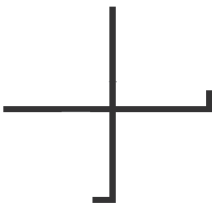

XCM-75-75	3.25	-	4.68	-	100	.22
XCM-75-75-150	5.15	-	7.10	-	100	.37
XDM-50-50	3.00	-	4.43	-	100	.19
XDM-625-625	3.08	-	4.50	-	100	.21
PXM-75-75	4.00	-	5.30	-	100	.28

"X" Inside Corner

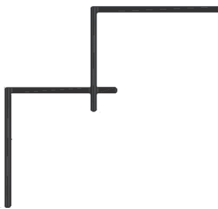

PIXM-75-75	5.29	-	7.24	-	100	.28
------------	------	---	------	---	-----	-----

Corner Key

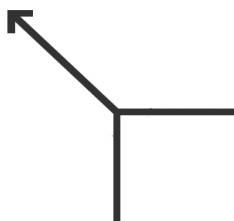

PCM-75-75	2.98	-	4.61	-	100	.19
PCM-75-75-150	4.11	-	6.36	-	100	.20

Foundation Weep	Molding Number	Clr Anod or Chem Film Non-Vented	Clr Anod or Chem Film Vented	Factory Painted Finish Non-Vented	Factory Painted Finish Vented	LF per Box	Pounds per foot
	FWS-75 Gray PVC	3.68	-	-	-	250	.20
	FWS-75A (Aluminum)	4.73	-	-	-	250	.37

E.I.F.S. Channel Screed	PCS-25-75	3.00	3.48	4.51	5.09	200	.19
	PCS-25-150	3.58	4.02	5.33	5.86	200	.23



E.I.F.S. Soffit Vent	PCS-75-V-300	-	7.00	-	9.21	100	.50
	PCS-75-V-400	-	7.98	-	10.78	100	.58
	PCS-75-V-600	-	11.94	-	15.40	100	.88



Clean Finish	VFS-600	-	-	-	4.88	300	.19
E.I.F.S. Soffit Vent	SV-75-V-300	-	7.14	-	9.07	100	.38
	SV-50-V-200	-	5.34	-	7.12	100	.27
	SV-50-V-300	-	6.60	-	8.48	100	.33
	SV-50-V-400	-	8.50	-	10.81	100	.39

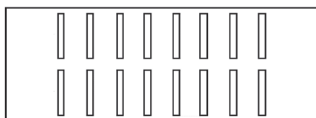

VFS



SV

VFS 600 only available in Gray polyester paint
 VFS 600 available with 5-row or 8-row vent pattern

E.I.F.S. Drip Screed	DS-75-200	6.36	6.83	8.64	9.16	100	.43
	DS-75-300	7.24	7.74	9.14	9.73	100	.50



Stucco Trims & Moldings - E.I.F.S. / Veneer Plaster (Priced per Linear Foot)

E.I.F.S. Drip Screed



Molding Number	Clr Anod or Chem Film Non-Vented	Clr Anod or Chem Film Vented	Factory Painted Finish Non-Vented	Factory Painted Finish Vented	LF per Box	Pounds per foot
DS-875-200	7.89	8.36	9.49	10.06	100	.56
DS-875-300	8.89	9.38	10.78	11.38	100	.63
DS-875-5/8-300*	8.67	9.19	11.53	12.14	100	1.07

Special 5/8" opening to receive 1/2" or 5/8" gypsum board with an E.I.F.S. finish coat.

E.I.F.S. Drip Screed

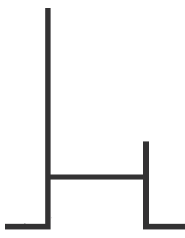

DS-75-75	3.58	4.00	5.12	5.61	200	.25
DS-375-875	4.22	4.63	5.60	6.07	200	.28
DS-875-875	4.31	4.69	5.84	6.31	200	.31
DS-875-150	6.72	7.14	8.34	8.89	100	.47

Veneer Plaster Reveal Molding



VPR-375-375	2.92	-	4.25	-	300	.17
VPR-50-50	3.11	-	4.45	-	300	.19
VPR-50-75	3.35	-	4.66	-	300	.21
VPR-50-150	3.79	-	5.09	-	300	.25
VPR-625-375	3.11	-	4.45	-	250	.19
VPR-625-50	3.33	-	4.65	-	250	.20
VPR-625-625	3.40	-	4.70	-	300	.21
VPR-625-75	3.53	-	4.84	-	300	.22

Veneer Plaster "F" Reveal Molding



VPRF-375-375	2.22	-	3.53	-	300	.14
VPRF-50-50	2.36	-	3.66	-	300	.15
VPRF-50-75	2.56	-	3.86	-	300	.16
VPRF-625-375	2.35	-	3.66	-	300	.15
VPRF-625-50	2.55	-	3.78	-	300	.16
VPRF-625-625	2.59	-	3.90	-	300	.17
VPRF-625-75	2.77	-	4.05	-	300	.18

Veneer Plaster "Z" Reveal Molding



VPRZ-375-375	1.78	-	3.07	-	250	.11
VPRZ-50-50	1.86	-	3.14	-	250	.11
VPRZ-50-75	2.06	-	3.36	-	250	.13
VPRZ-625-375	1.86	-	3.14	-	250	.10
VPRZ-625-50	3.33	-	4.65	-	250	.12
VPRZ-625-625	2.08	-	3.39	-	250	.13
VPRZ-625-75	3.53	-	4.84	-	250	.13

Stucco Trims & Moldings - Transition Trims

(Priced per Linear Foot)

Stucco Retainer



Molding Number	Clr Anod or Chem Film Non-Vented	Clr Anod or Chem Film Vented	Factory Painted Finish Non-Vented	Factory Painted Finish Vented	LF per Box	Pounds per foot
PCS-RET	2.22	-	-	-	100	.18

Stucco Insert



PCS-INS75	2.56	-	3.42	-	100	.21
-----------	------	---	------	---	-----	-----

Stucco Transition Insert



PCS-TRANS INS	2.06	-	2.92	-	100	.17
---------------	------	---	------	---	-----	-----

Stucco Inside Corner Transition

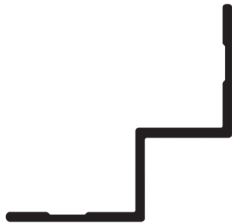

PCS-I/SCRNTR	2.05	-	3.20	-	100	.16
--------------	------	---	------	---	-----	-----

Stucco Inside Corner Transition 3/4"

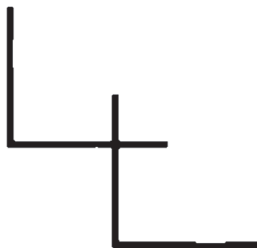

PCS-I/SCRNTR750	3.46	-	4.83	-	100	.27
-----------------	------	---	------	---	-----	-----

Stucco Outside Corner Transition

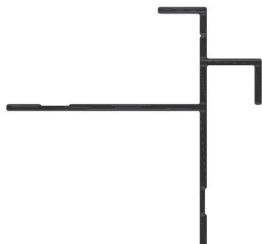

PCS-O/SCRNTR	3.49	-	5.19	-	100	.25
--------------	------	---	------	---	-----	-----

Veneer Plaster Moldings / Glazing Track

(Priced per Linear Foot)

Contemporary Reveal Veneer Plaster



U.S. Patent No. 452016

Molding Number	Clr Anod or Chem Film Non-Vented	Clr Anod or Chem Film Vented	Factory Painted Finish Non-Vented	Factory Painted Finish Vented	LF per Box	Pounds per foot
CVPR-50-50	8.23	-	-	-	200	.50
CVPR-50-100	7.66	-	-	-	200	.46
CVPR-625-50	8.55	-	-	-	200	.52
CVPR-625-75	7.97	-	-	-	200	.50
CVPR-625-100	7.69	-	-	-	200	.49

Contemporary Reveal Drywall



U.S. Patent No. 452016

CDRM-50-50	8.23	-	-	-	200	.48
CDRM-50-75	7.94	-	-	-	200	.48
CDRM-50-100	7.66	-	-	-	200	.46
CDRM-625-50	8.55	-	-	-	200	.52
CDRM-625-75	7.97	-	-	-	200	.50
CDRM-625-100	7.69	-	-	-	200	.49

Acoustical Wall Angle



WA75100	2.16	-	3.43	-	250	0.12
WA100200	3.16	-	4.58	-	250	0.21

Drywall Glazing Track

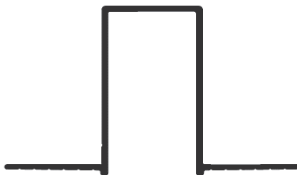

DRM 150-75	5.56	-	6.04	-	100	.26
------------	------	---	------	---	-----	-----

Acoustical Glazing Track

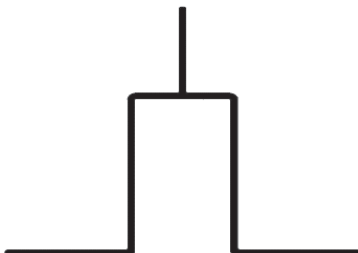

ARM 150-75	5.85	-	7.64	-	100	0.39
------------	------	---	------	---	-----	------

Glazing Track (Priced per Linear Foot)

(Priced per Linear Foot)

Acoustical / Drywall Glazing Track

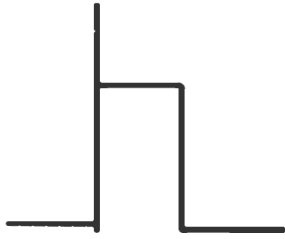

Molding Number	Clr Anod or Chem Film Non-Vented	Clr Anod or Chem Film Vented	Factory Painted Finish Non-Vented	Factory Painted Finish Vented	LF per Box	Pounds per foot
DRMAD 150-75	5.85	-	7.67	-	100	0.38

Drywall Glazing Track



DMGT-3500	9.93	-	14.77	-	100	0.59
DMGT-3750	10.17	-	14.97	-	100	0.61
DMGT-4625	10.85	-	-	-	100	0.67
DMGT-4875	11.07	-	15.88	-	100	0.69
DMGT-7250	19.28	-	24.08	-	100	1.57

Drywall Glazing End Closure



DMEC-3500	4.43	-	6.65	-	200	0.32
DMEC-3750	5.28	-	7.35	-	100	0.41
DMEC-4625	6.08	-	8.39	-	100	0.47
DMEC-4875	6.32	-	8.66	-	100	0.49
DMEC-7250	12.79	-	17.04	-	100	1.08

Drywall Glazing Track Roll-in Vinyl Gasket

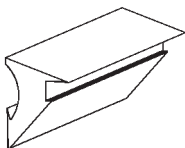

Gasket Number	Gasket Use	Price Per Foot	LF per Roll	Pounds Per Roll
RR 3657	for use with 1/4" glass	295.00	250	16
RR 3654	for use with 3/8" glass	439.00	500	18
RR 3730	for use with 1/2" glass	370.00	500	11

**** ONLY AVAILABLE IN BLACK ****

IFR Reveal Retainer



Molding Number	Clear Anodized or Chem Film	Factory Painted Finish	LF per Box	Std Lengths	Pounds per foot
IFR REVEAL	5.38	-	100	10'	0.56

*** END CAP REQUIRED AT TERMINATION**

IFR End Caps

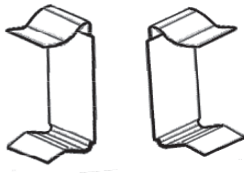

IFRRVLEND CAP	11.60	-	EA	N/A	N/A
---------------	-------	---	----	-----	-----

*** END CAP SOLD IN PAIRS**

IFR Hook Insert



IFR HOOK INSERT	4.63	-	EA	N/A	N/A
-----------------	------	---	----	-----	-----

CHART RAIL



IFR2CHARTRAIL *	5.80	-	100	10'	0.41
IFR3CHARTRAIL	6.64	-	100	10'	0.43

*** Old part # IFRCHARTRAIL**

CHART RAIL END CAP

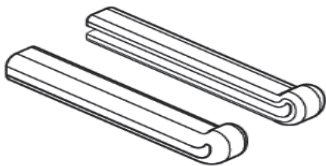

IFR2CHRAILEC	29.76	-	EA	N/A	N/A
IFR3CHRAILEC	36.40	-	EA	N/A	N/A

*** END CAP SOLD IN PAIRS**

RAIL CLIP



IFRRAILCLIP	2.07	-	EA	N/A	N/A
-------------	------	---	----	-----	-----

*** 4 RAIL CLIPS PER 10' PIECE OF CHARTRAIL**